



### AH-SERIES

MODEL	THERAD	FAN DIA.	FLOW	CAPACITY	HYDRAULIC SYSTEM	DIMENSION	WEIGHT	PHASE	SAFETY REF.	PAGE
	RC/PT	m.m./Inch	ℓ/Min./U.S.GAL.	ΔT = 30°C	HP/kW	LxHxW	Kg			
AH0608T-CA*	3/4"	150/6"	3~60/0.8~15.9	1,200	1~2/0.74~1.5	305x200x115	4.2	SINGLE	CE	335
AH0608LT-CA*	3/4"	150x2/6"x2	3~60/0.8~15.9	2,400	2~3/1.5~2.2	405x200x115	6.0	SINGLE	CE	335
AH1012-CA*	1"	250/10"	20~100/5.3~26.4	5,000	3~5/2.2~3.7	417x360x200	10.0	SINGLE	CE	335
AH-1012-3P-CA*	1"	250/10"	20~100/5.3~26.4	5,500	3~5/2.2~3.7	417x360x200	10.0	3	CE	335
AH1215-CA*	1"	300/12"	20~100/5.3~26.4	7,000	5~7.5/3.7~5.6	510x390x210	15.0	3	CE	336
AH1417-A*	1"	350/14"	30~100/7.9~26.4	9,000	7.5~10/5.6~7.5	570x411x200	11.0	SINGLE		336
AH1418-CA*	1"	350/14"	30~200/7.9~52.8	10,000	7.5~10/5.6~7.5	570x420x200	17.0	3	CE	336
AH1428-CA*	1-1/4"	350/14"	30~200/7.9~52.8	13,000	15~20/11.2~14.9	570x420x230	21.0	3	CE	337
AH1470-A*	1-1/4"	350/14"	30~100/7.9~26.4	11,000	10~15/7.5~11.2	570x407x225	13.0	SINGLE		337
AH1470-CA*	1-1/4"	350/14"	30~200/7.9~52.8	13,000	15~20/11.2~14.9	520x475x320	25.0	3		337
AH1490-CA*	1-1/2"	350/14"	30~200/7.9~52.8	16,000	20~25/14.9~18.6	520x640x300	30.0	3	CE	338
AH1680-CA*	1-1/2"	400/16"	30~250/7.9~66.0	21,000	25~40/18.6~29.8	520x640x320	35.0	3	CE	338
AH1890-CA*	1-1/2"	450/18"	30~250/7.9~66.0	25,000	30~50/22.4~37.3	650x800x380	52.0	3	CE	338
AH2342-CA*	1-1/2"	560/23"	50~250/13.2~66.0	37,000	50~75/37.3~55.9	605x935x543	80.0	3	CE	339
AH2583-CA*	RP1-1/2"	630/25"	100~350/26.4~92.5	50,000	75~100/55.9~74.5	645x950x630	100.0	3	CE	339
AH2890-CA*	1-1/2"	560/23"	100~350/26.4~92.5	60,000	100~125/74.5~93.1	875x1000x900	150.0	3	CE	340
AH3-2583-CA*	1-1/2"	630x3/25"x3	100~350/26.4~92.5	140,000	300/223.5	875x2400x700	300.0	3	CE	340

### AW-SERIES

MODEL	THERAD	FLOW	Max. Pressure	CAPACITY	DIMENSION	WEIGHT	PHASE	SAFETY REF.	PAGE
	RC/PT	ℓ/Min./U.S.GAL.	Bar/psi	ΔT = 30°C	LxHxW	Kg			
AW0607-CA*	1/2"	20/5.3	15/217.5	700	250x200x108	3.3	SINGLE	CE	341
AW0608-CA*	1/2"	20/5.3	15/217.5	900	310x200x108	3.7	SINGLE	CE	341
AW0608L-CA*	1"	20/5.3	15/217.5	1500	410x200x108	5.2	SINGLE	CE	341

### AL-SERIES

MODEL	THERAD	FLOW	Max. Pressure	CAPACITY	DIMENSION	WEIGHT	PHASE	SAFETY REF.	PAGE
	RC/PT	ℓ/Min./U.S.GAL.	Bar/psi	ΔT = 30°C	LxHxW	Kg			
AL404	1/2"	10/2.64	10/145		250x203x67	1.0			342
AL404-A*	1/2"	10/2.64	10/145	1100	250x203x120	2.25	SINGLE		342
AL404-CA*	1/2"	10/2.64	10/145	1200	250x203x120	2.85	SINGLE	CE	342
AL404-4A*	1/2"	10/2.64	10/145	800	250x203x98	1.75	SINGLE		342
AL608	3/8"	10/2.64	10/145		250x203x57	0.75			342
AL608-A*	3/8"	10/2.64	10/145	800	250x203x110	2.0	SINGLE		342
AL608-CA*	3/8"	10/2.64	10/145	900	250x203x110	2.6	SINGLE	CE	342
AL608-4A*	3/8"	10/2.64	10/145	600	250x203x88	1.5	SINGLE		343
AL190	3/8"	10/2.64	10/145		220x167x56	0.5			342
AL609	1/2"	10/2.64	10/145		250x203x57	0.75			342

## 【INTRODUCTION】

Nowadays, more and more air cooling system were applied in oil cooling system because water cooling cost is too high and same areas are not easy to secure water. Even more water treatment and discharge is also very difficult and expensive. Air-Oil plate-fin heat exchanger has the characteristics of water-free, clean, compact, light weight and very easy for piping, please take the following information for reference.

	ENVIRONMENT PROTECT	CONSUME OF ENERGY	DEMAND OF WATER	COST OF INSTALLATION		MAINTAIN	COOLING CAPACITY	INFLUENCE OF BREAKDOWN	INSTALLATION
				FACTORY	END USER				
AIR-OIL	SUPERIOR	LESS	X	LARGE	NONE	LESS	NO LIMIT	LESS	EASY
WATER-OIL	INFERIOR	MEDIUM	O	LESS	HUGE	HUGE	GOOD	WATER MIX WITH OIL	HARD
FREEZE	INFERIOR	LARGE	X	HUGE	NONE	MEDIUM	LIMIT	LESS	EASY

SOLTECH provides 3 different series Air-Oil plate-fin heat exchanger. There heat exchanger could be applied in drain system or return line systems with high quality and perfect cooling efficiency.

**AL series:** For low pressure variable pump(under 70 Bar), drain circuit only.

Max. working pressure: 10 Bar, Flow Rate: 3-60 L/Min

**AW series:** For low pressure variable pump drain circuit, or separated cooling systems.

Max. working pressure: 15 Bar, Flow Rate: 3-60 L/Min

**AH series:** For return line circuit/drain circuit, or separated cooling systems.

Max. dynamic/static working pressure: 20/30 Bar, Flow Rate: 3-350 L/Min



### INSTALLATION

1. Air-Oil heat exchanger should be mounted in a position that could avoid vibration and impact, and make sure that air can be flow freely. Prevents to mount it close to other heat source. Please refers to figure no. 1.
2. When use the heat exchanger, "A BY-PASS CIRCUIT" was strongly recommend. Especially when use our AH series as return line cooling system. Please refers to figure no. 2. This by-pass circuit could protects heat exchanger when surge pressure happen.
3. When fastening the adaptor of in/out ports, please use an adjustable wrenches to hold-on the ports. Because both ports also made by aluminum, and could be damaged when without a tool to hold-on when twist.
4. For keeping the heat exchanger in high efficiency, please clean the radiator once a week if possible. It can be done by compressed air. Please be sure the jet runs in usual direction and the electric motor must be dicconnect to the power and in good protection.

FIGURE NO. 1

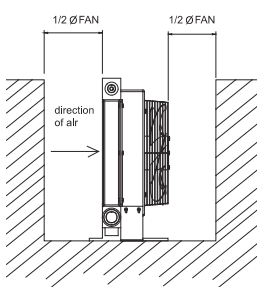

FIGURE NO. 2

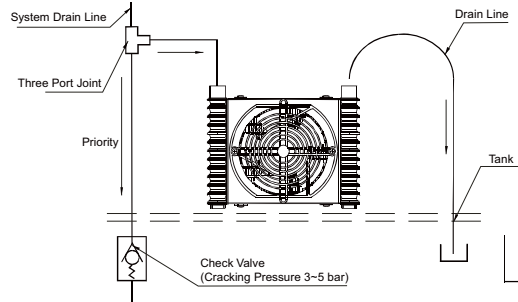

FIGURE NO. 3: VARIABLE PUMP

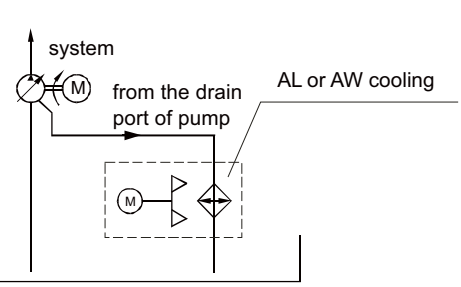

FIGURE NO. 4:  
FIX DIS. PUMP

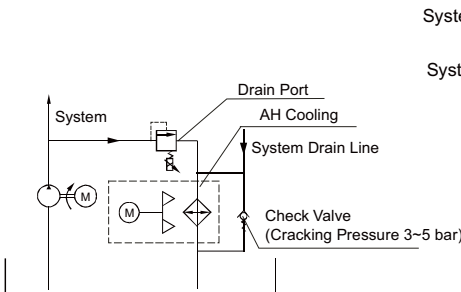

FIGURE NO. 5  
By-Pass Circuit

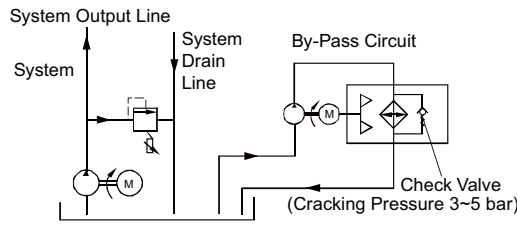
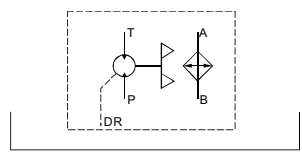

FIGURE NO. 6  
HYDRAULIC MOTOR



### HOW TO CHOOSE YOUR HEAT EXCHANGER

The overall efficiency of most hydraulic system is app..70~85%, it means that 15 ~ 30% of power convert to heat and must be dissipated by the heat exchanger. When choosing a heat exchanger, an over estimate of 15~20% is necessary. When dust cover the fin, the cooling efficiency will be lower.

### FORMULA

N = installed power in the system (kW)  
 Q = heat to be dissipated (kcal/h)  
 To = maximum allowed oil temperature (°C)  
 Tamb = ambient temperature (°C)  
 Kr : means the required specific performance of heat-exchanger.  
 $Kr = Q / \Delta T$ , dove  $\Delta T$  is the difference between oil inlet temperature and summer ambient temperature, while Q is the quantity of heat to be dissipated which can be easily calcaulted considering 20~30% of installed power.

### EXAMPLE

N = 20 kW, To = 50°C, Tamb = 35°C,  
 Q = 70% x 20kW = 14 kW = 12040 kcal/h  
 $\Delta T = 50 - 35 = 15^\circ C$   
 $Kr = 12040 / 15 = 803 \text{ kcal/h}^\circ C = 0.93 \text{ kW}^\circ C$   
 The choice of the correct cooler is made using the diagrams you will find in our technical catalogues.

### EQUIVALENTS AMONG MAIN UNITS

1 HP = 635 kcal/h,      1kW = 860 kcal/h  
 1 BTU = 0.35 kcal/h      1 cST = 1 mm²/sec



# ACCESSORIES

## AIR-OIL PLATE-FIN HEAT EXCHANGER- DRAIN TYPE

### ※SPECIFICATION

DESCRIPTION	UNIT	AC 115V	AC 230V	AC 380V	DC 12V	DC 24V
FREQUENCY	Hz	50/60	50/60	50/60	---	---
POWER	W	45/37	45/37	30/25	---	---
CURRENT	A	0.5/0.6	0.27/0.23	---	2.5	0.58
SPEED	R.P.M.	2850/3450	2850/3450	---	3350	3350
AIR-FLOW	m <sup>3</sup> /h	457/553	457/553	---	500	420
PROTECTION		IP54	IP54	---	---	---
NOISE	dB(A)	42/48	42/48	---	51	51
SAFETY REF.		CE	CE	---	---	---

### 【AH0608T-CA\*】

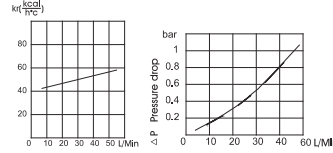

### ※MODEL NUMBER DESIGNATION

AH	06	08T	C	A1
Series No.	Fan Size	Radiator Model No.	Fan Case	Voltage A1: AC 115V A2: AC 230V A3: AC 380V D1: DC 12V D2: DC24V

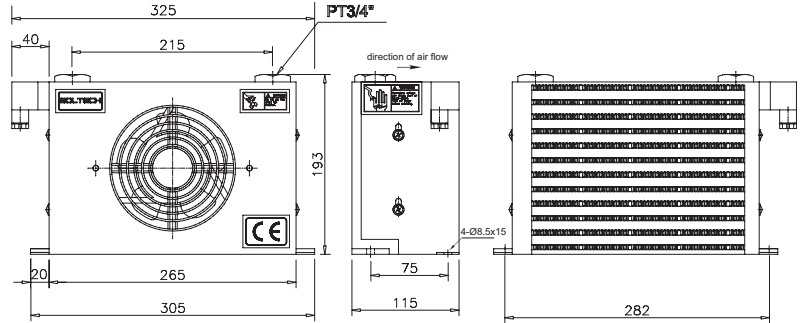

### ※SPECIFICATION

DESCRIPTION	UNIT	AC 115V	AC 230V	AC 380V	DC 12V	DC 24V
FREQUENCY	Hz	50/60	50/60	50/60	---	---
POWER	W	45/37	45/37	30/25	---	---
CURRENT	A	0.5/0.6	0.27/0.23	---	2.5	0.58
SPEED	R.P.M.	2850/3450	2850/3450	---	3350	3350
AIR-FLOW	m <sup>3</sup> /h	457/553	457/553	---	500	420
PROTECTION		IP54	IP54	---	---	---
NOISE	dB(A)	42/48	42/48	---	51	51
SAFETY REF.		CE	CE	---	---	---

### 【AH0608LT-CA\*】

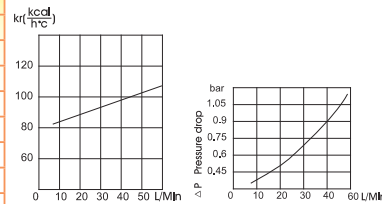

### ※MODEL NUMBER DESIGNATION

AH	06	08LT	C	A1
Series No.	Fan Size	Radiator Model No.	Fan Case	Voltage A1: AC 115V A2: AC 230V A3: AC 380V D1: DC 12V D2: DC24V

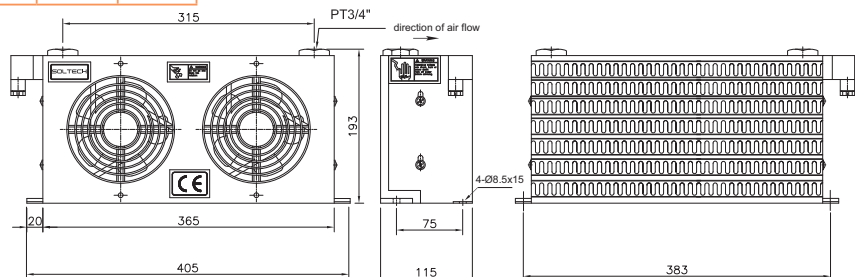

### ※SPECIFICATION

DESCRIPTION	UNIT	AC 115V	AC 230V	AC 400V	DC 12V	DC 24V
PHASE		SINGLE	SINGLE	THREE	THREE	---
FREQUENCY	Hz	50/60	50/60	50/60	50/60	---
POWER	W	16	16	---	---	---
CURRENT	A	0.8/0.74	0.42/0.36	0.28/0.23	0.16/0.13	5.5
SPEED	R.P.M.	1300/1550	1300/1550	1430/1670	1430/1670	2000
AIR-FLOW	m <sup>3</sup> /h	840/1000	840/1000	1000/1200	1000/1200	---
PROTECTION		IP42	IP42	IP54	IP54	---
NOISE	dB(A)	---	---	55	55	---
SAFETY REF.		CE	CE	CE	CE	---

### 【AH1012-CA\*】

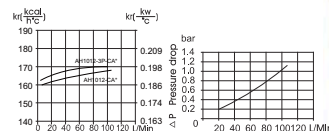

### ※MODEL NUMBER DESIGNATION

AH	10	12	(3P)	C	A1
Series No.	Fan Size	Radiator Model No.	Omit: Single Phase 3P: 3 Phase	Fan Case	Voltage A1: AC 115V A2: AC 230V D1: DC 12V D2: DC24V A2: AC 230V A4: AC 400V

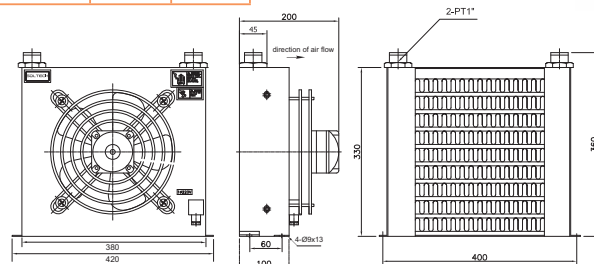



# ACCESSORIES

## AIR-OIL PLATE-FIN HEAT EXCHANGER

### ※SPECIFICATION

DESCRIPTION	UNIT	AC 230V	AC 400V
FREQUENCY	Hz	50/60	50/60
POWER	W	---	---
CURRENT	A	0.45/0.50	0.26/0.29
SPEED	R.P.M.	2420/2510	2420/2510
AIR-FLOW	m <sup>3</sup> /h	1800/1900	1800/1900
PROTECTION		IP54	IP54
NOISE	dB(A)	60	60
SAFETY REF.		CE	CE

### 【AH1215-CA\*】

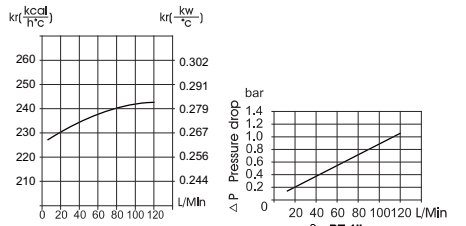

### ※MODEL NUMBER DESIGNATION

AH	12	15	C	A2
Series No.	Fan Size	Radiator Model No.	Fan Case	Voltage A2: AC 230V A3: AC 400V

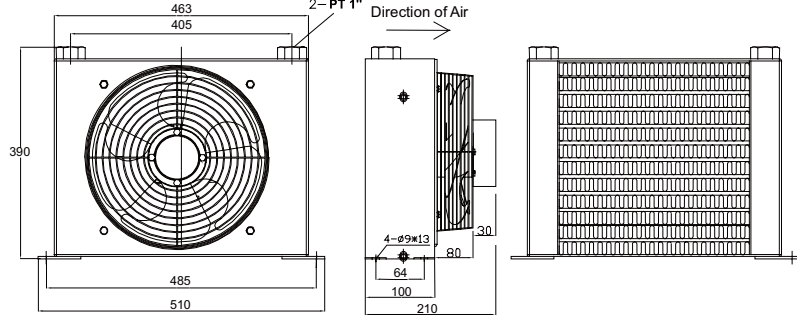

### ※SPECIFICATION

DESCRIPTION	UNIT	AC 115V	AC 230V	DC 12V	DC 24V
FREQUENCY	Hz	50/60	50/60	---	---
POWER	W	40/50	40/50	---	---
CURRENT	A	---	---	7.5	4.5
SPEED	R.P.M.	1450/1650	1450/1650	2000	2200
AIR-FLOW	m <sup>3</sup> /h	2300/2760	2300/2760	---	---
PROTECTION		---	---	---	---
NOISE	dB(A)	---	---	---	---
SAFETY REF.		---	---	---	---

### 【AH1417-A\*】

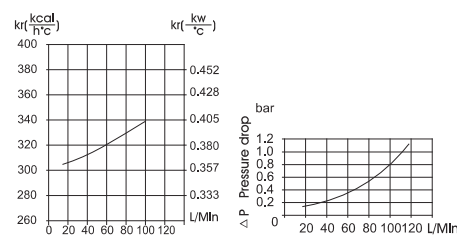

### ※MODEL NUMBER DESIGNATION

AH	14	17	A1
Series No.	Fan Size	Radiator Model No.	Voltage A1: AC 115V A2: AC 230V D1: DC 12V D2: DC 24V

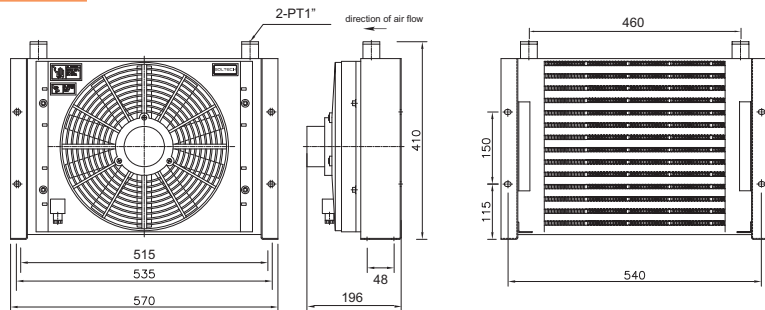

### ※SPECIFICATION

DESCRIPTION	UNIT	AC 230V	AC 400V	AC 440V
FREQUENCY	Hz	50/60	50/60	50/60
POWER	W	150/180	150/180	200/260
CURRENT	A	0.80/0.70	0.40/0.36	0.40/0.43
SPEED	R.P.M.	1380/1550	1380/1550	1380/1560
AIR-FLOW	m <sup>3</sup> /h	3200/3800	3200/3800	3200/3800
PROTECTION		IP54	IP54	IP54
NOISE	dB(A)	62	62	62
SAFETY REF.		CE	CE	CE

### 【AH1418-CA\*】

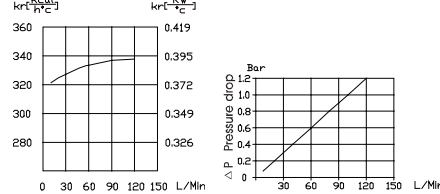

### ※MODEL NUMBER DESIGNATION

AH	14	18	C	A2
Series No.	Fan Size	Radiator Model No.	Fan Case	Voltage A2: AC 230V A4: AC 400V

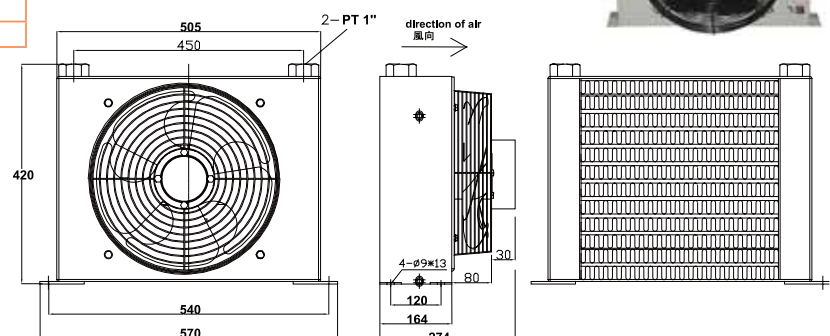



### ※SPECIFICATION

DESCRIPTION	UNIT	AC 230V	AC 400V	AC 440V
FREQUENCY	Hz	50/60	50/60	50/60
POWER	W	150/180	150/180	200/260
CURRENT	A	0.80/0.70	0.40/0.36	0.40/0.43
SPEED	R.P.M.	1380/1550	1380/1550	1380/1560
AIR-FLOW	m <sup>3</sup> /h	3200/3800	3200/3800	3200/3800
PROTECTION		IP54	IP54	IP54
NOISE	dB(A)	62	62	62
SAFETY REF.		CE	CE	CE

### 【AH1428-CA\*】

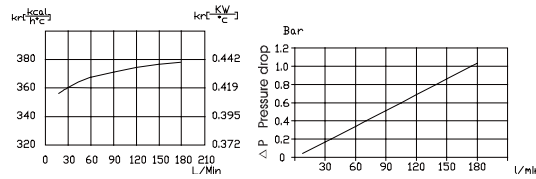

### ※MODEL NUMBER DESIGNATION

AH	14	28	C	A2
Series No.	Fan Size	Radiator Model No.	Fan Case	Voltage A2: AC 230V A4: AC 440V

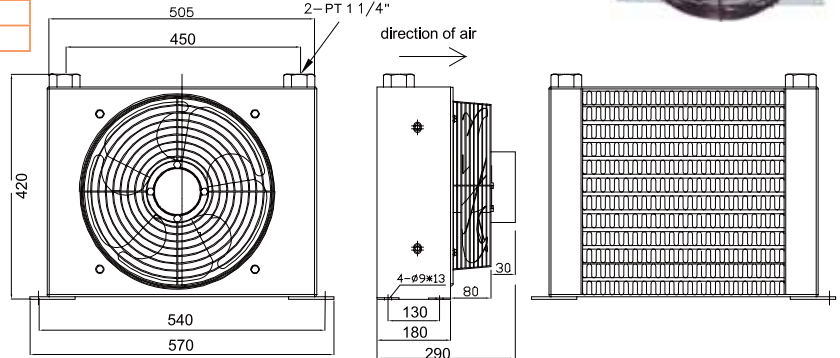

### ※SPECIFICATION

DESCRIPTION	UNIT	AC 115V	AC 230V	DC 12V	DC 24V
FREQUENCY	Hz	50/60	50/60	---	---
POWER	W	40/50	40/50	---	---
CURRENT	A	---	---	7.5	4.5
SPEED	R.P.M.	1450/1650	1450/1650	2000	2200
AIR-FLOW	m <sup>3</sup> /h	2300/2760	2300/2760	---	---
PROTECTION		---	---	---	---
NOISE	dB(A)	---	---	---	---
SAFETY REF.		---	---	---	---

### 【AH1470-A\*】

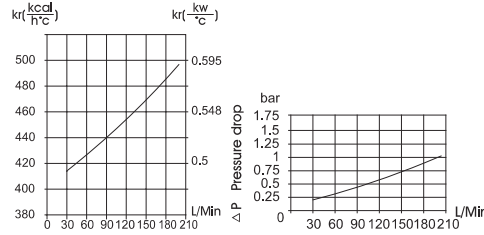

### ※MODEL NUMBER DESIGNATION

AH	14	70	A1
Series No.	Fan Size	Radiator Model No.	Voltage A1: AC 115V A2: AC 230V D1: DC 12V D2: DC24V

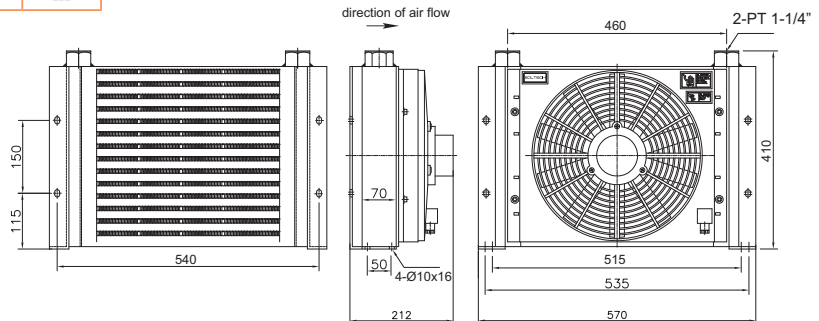

### ※SPECIFICATION

DESCRIPTION	UNIT	AC 230V	AC 380V
FREQUENCY	Hz	50/60	50/60
POWER	Hp	1/2	1/2
CURRENT	A	---	---
SPEED	R.P.M.	1380/1550	1380/1550
AIR-FLOW	m <sup>3</sup> /h	2400/2880	2400/2880
PROTECTION		---	---
NOISE	dB(A)	---	---
SAFETY REF.		---	---

### 【AH1470-CA\*】

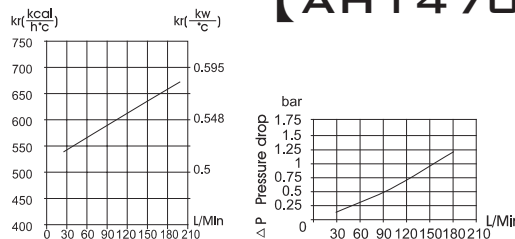

### ※MODEL NUMBER DESIGNATION

AH	14	70	C	A2
Series No.	Fan Size	Radiator Model No.	Fan Case	Voltage A2: AC 230V A3: AC 380V AC 400/ 415/ 440/ 480 is also available

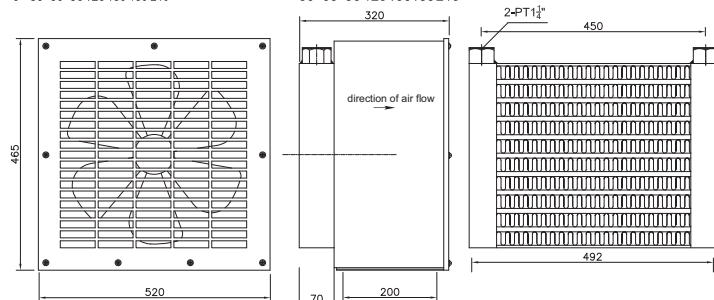





# ACCESSORIES

## AIR-OIL PLATE-FIN HEAT EXCHANGER

### ※SPECIFICATION

DESCRIPTION	UNIT	AC 230V	AC 400V	AC 440V
FREQUENCY	Hz	50/60	50/60	50/60
POWER	W	150/180	150/180	200/260
CURRENT	A	0.80/0.70	0.40/0.36	0.40/0.43
SPEED	R.P.M.	1380/1550	1380/1550	1380/1560
AIR-FLOW	m <sup>3</sup> /h	3200/3800	3200/3800	3200/3800
PROTECTION		IP54	IP54	IP54
NOISE	dB(A)	62	62	62
SAFETY REF.		CE	CE	CE

### 【AH1490-CA\*】

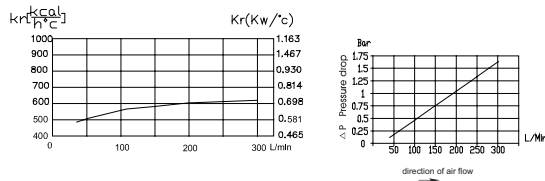

### ※MODEL NUMBER DESIGNATION

AH	14	90	C	A2
Series No.	Fan Size	Radiator Model No.	Fan Case	Voltage
				A2: AC 230V
				A4: AC 400V

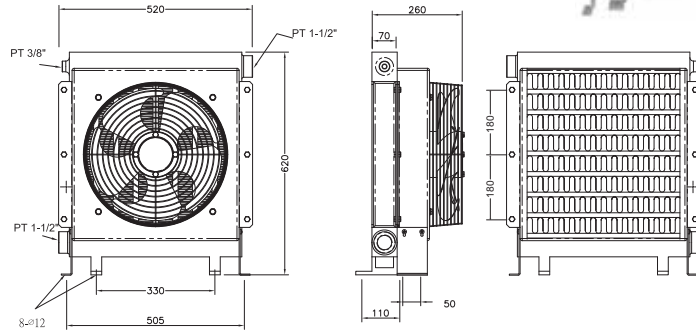

### ※SPECIFICATION

DESCRIPTION	UNIT	AC 230V	AC 400V	AC 440V
FREQUENCY	Hz	50/60	50/60	50/60
POWER	W	145/250	145/250	135/175
CURRENT	A	0.90/1.00	0.50/0.52	0.28/0.30
SPEED	R.P.M.	1380/1550	1380/1550	1380/1570
AIR-FLOW	m <sup>3</sup> /h	4000/4800	4000/4800	4000/4800
PROTECTION		IP54	IP54	IP54
NOISE	dB(A)	68	68	68
SAFETY REF.		CE	CE	CE

### 【AH1680-CA\*】

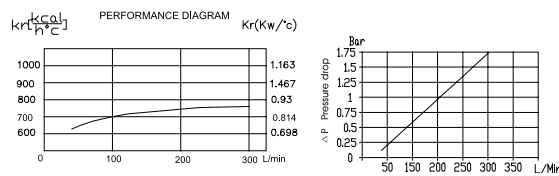

### ※MODEL NUMBER DESIGNATION

AH	16	80	C	A2
Series No.	Fan Size	Radiator Model No.	Fan Case	Voltage
				A2: AC 230V
				A4: AC 400V

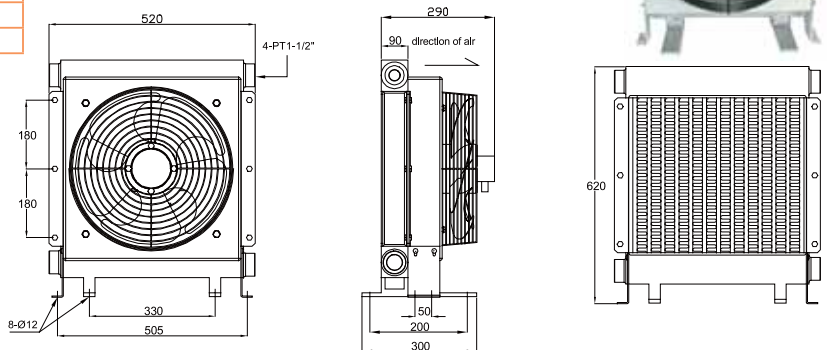

### ※SPECIFICATION

DESCRIPTION	UNIT	AC 230V	AC 400V	AC 440V
FREQUENCY	Hz	50/60	50/60	50/60
POWER	W	250/350	250/350	210/300
CURRENT	A	1.1/1.2	0.65/0.70	0.45/0.51
SPEED	R.P.M.	1350/1500	1350/1500	1380/1560
AIR-FLOW	m <sup>3</sup> /h	5200/6200	5200/6200	5200/6200
PROTECTION		IP54	IP54	IP54
NOISE	dB(A)	72	72	72
SAFETY REF.		CE	CE	CE

### 【AH1890-CA\*】

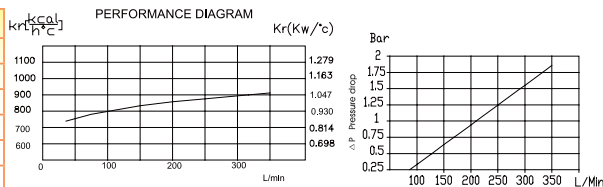

### ※MODEL NUMBER DESIGNATION

AH	18	90	C	A2
Series No.	Fan Size	Radiator Model No.	Fan Case	Voltage
				A2: AC 230V
				A4: AC 400V

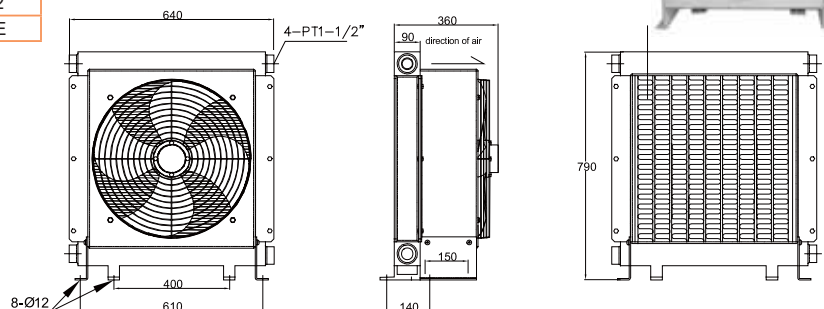



### ※SPECIFICATION

DESCRIPTION	UNIT	AC	
		210~230/360~400V	240~270/420~460V
FREQUENCY	Hz	50	60
POWER	W	1.5kW, 2Hp	1.72kW, 2Hp
CURRENT	A	6.15~6.25/2.56~3.78	6.15~6.25/2.56~3.78
SPEED	R.P.M.	1400	1680
AIR-FLOW	m <sup>3</sup> /h	7600	9120
PROTECTION		IP55	IP55
NOISE	dB(A)	---	---
SAFETY REF.		CE	CE

### ※MODEL NUMBER DESIGNATION

AH	23	42	C	A2
Series No.	Fan Size	Radiator Model No.	Fan Case	Voltage A2: AC 230V A3: AC 380V AC 400/ 415/ 440 is also available

### 【AH2342-CA\*】

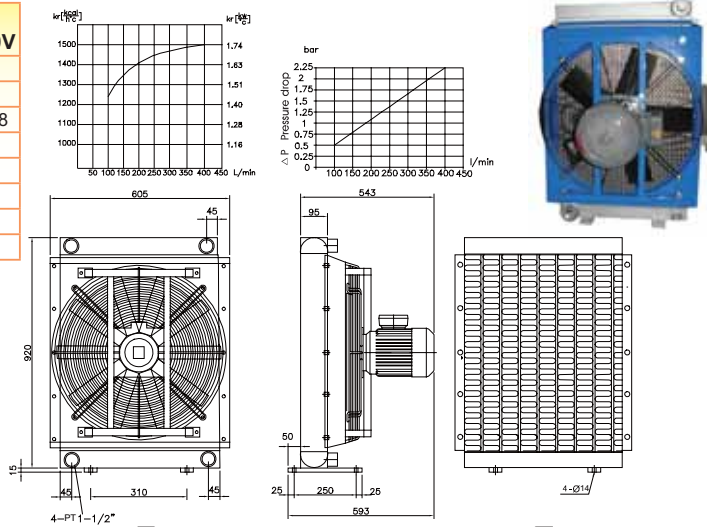

### ※SPECIFICATION

DESCRIPTION	UNIT	AC	
		210~230/360~400V	240~270/420~460V
FREQUENCY	Hz	50	60
POWER	W	1.5kW, 2Hp	1.72kW, 2Hp
CURRENT	A	6.15~6.25/2.56~3.78	6.15~6.25/2.56~3.78
SPEED	R.P.M.	1400	1680
AIR-FLOW	m <sup>3</sup> /h	7600	9120
PROTECTION		IP55	IP55
NOISE	dB(A)	---	---
SAFETY REF.		CE	CE

### ※MODEL NUMBER DESIGNATION

AH	23	42A	C	A2
Series No.	Fan Size	Radiator Model No.	Fan Case	Voltage A2: AC 230V A3: AC 380V AC 400/ 415/ 440 is also available

### 【AH2342A-CA\*】

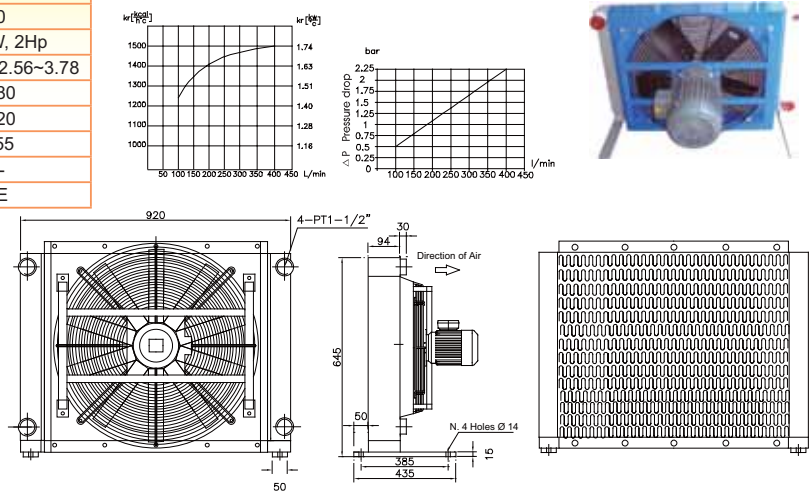

### ※SPECIFICATION

DESCRIPTION	UNIT	AC	
		210~230/360~400V	240~270/420~460V
FREQUENCY	Hz	50	60
POWER	W	2.2kW, 3Hp, 4Poles	2.53kW, 3Hp, 4Poles
CURRENT	A	8.6~9.15/5~5.29	8.6~9.15/5~5.29
SPEED	R.P.M.	1400	1680
AIR-FLOW	m <sup>3</sup> /h	10,000	12,000
PROTECTION		IP55	IP55
NOISE	dB(A)	---	---
SAFETY REF.		CE	CE

### ※MODEL NUMBER DESIGNATION

AH	25	83	C	A2
Series No.	Fan Size	Radiator Model No.	Fan Case	Voltage A2: AC 230V A3: AC 380V AC 400/ 415/ 440 is also available

### 【AH-2583-CA\*】

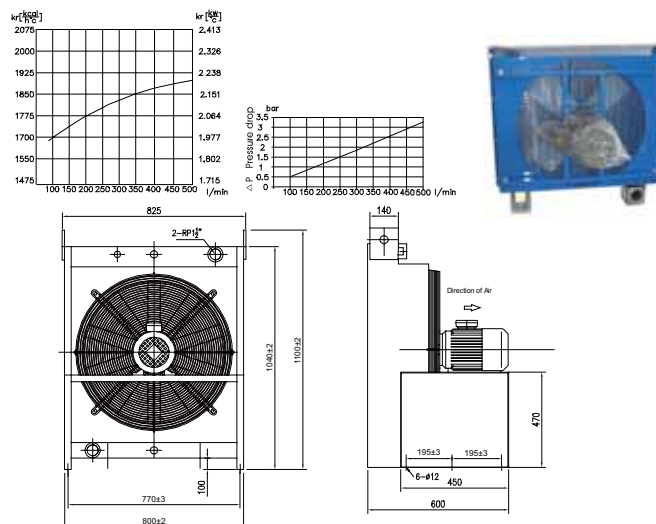



# ACCESSORIES

## AIR-OIL PLATE-FIN HEAT EXCHANGER

### ※SPECIFICATION

DESCRIPTION	UNIT	AC	
		210~230/360~400V	240~270/420~460V
FREQUENCY	Hz	50	60
POWER	W	2.2kW, 3Hp, 6Poles	2.6kW, 3Hp, 6Poles
CURRENT	A	9.89~9.51/5.71~5.49	9.89~9.51/5.71~5.49
SPEED	R.P.M.	955	1150
AIR-FLOW	m <sup>3</sup> /h	16,500	19,800
PROTECTION		IP55	IP55
NOISE	dB(A)	---	---
SAFETY REF.		CE	CE

### 【AH2890-CA\*】

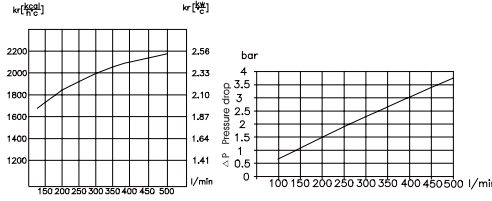

### ※MODEL NUMBER DESIGNATION

AH	28	90	C	A2
Series No.	Fan Size	Radiator Model No.	Fan Case	Voltage A2: AC 230V A3: AC 380V AC 400/ 415/ 440 is also available

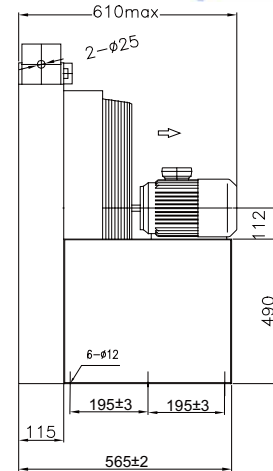
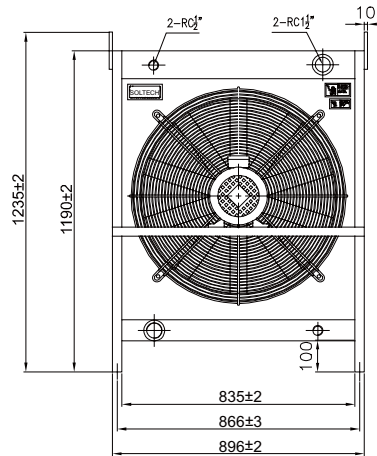

### ※SPECIFICATION

DESCRIPTION	UNIT	AC	
		210~230/360~400V	240~270/420~460V
FREQUENCY	Hz	50	60
POWER	W	2.2kW, 3Hp, 4Poles	2.53kW, 3Hp, 4Poles
CURRENT	A	8.6~9.15/5~5.29	8.6~9.15/5~5.29
SPEED	R.P.M.	1400	1680
AIR-FLOW	m <sup>3</sup> /h	10,000	12,000
PROTECTION		IP55	IP55
NOISE	dB(A)	---	---
SAFETY REF.		CE	CE

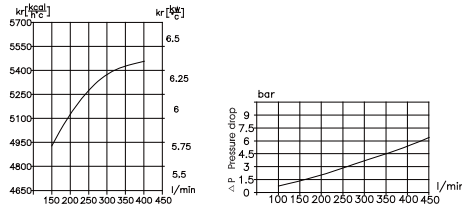

### ※MODEL NUMBER DESIGNATION

AH3	25	83	C	A2
Series No.	Fan Size	Radiator Model No.	Fan Case	Voltage A2: AC 230V A3: AC 380V AC 400/ 415/ 440 is also available

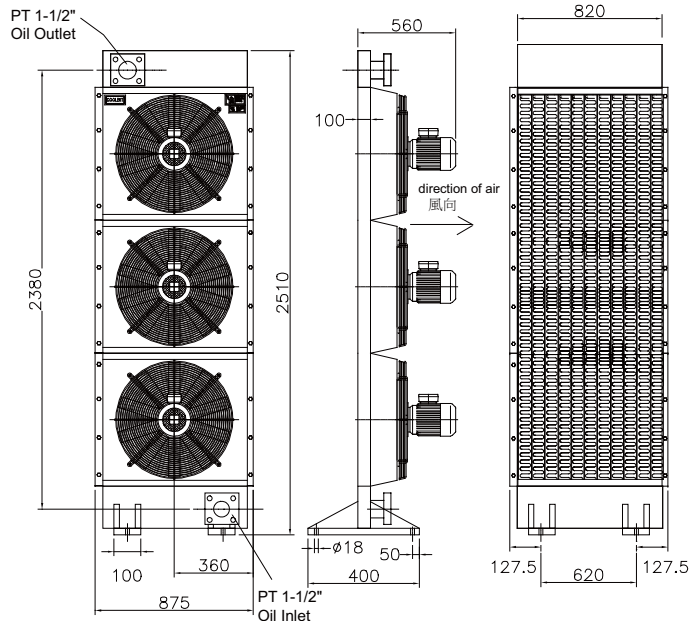





### ※SPECIFICATION

DESCRIPTION	UNIT	AC 115V	AC 230V	AC 380V	DC 12V	DC 24V
FREQUENCY	Hz	50/60	50/60	50/60	---	---
POWER	W	45/37	45/37	30/25	---	---
CURRENT	A	0.5/0.6	0.27/0.23	---	2.5	0.58
SPEED	R.P.M.	2850/3450	2850/3450	---	3350	3350
AIR-FLOW	m <sup>3</sup> /h	457/553	457/553	---	500	420
PROTECTION		IP54	IP54	---	---	---
NOISE	dB(A)	42/48	42/48	---	51	51
SAFETY REF.		CE	CE	---	---	---

### 【AW0607-CA\*】

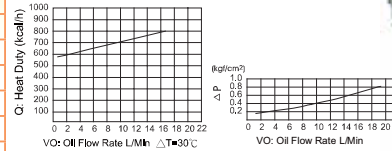

### ※MODEL NUMBER DESIGNATION

AW	06	07	C	A1
Series No.	Fan Size	Radiator Model No.	Fan Case	Voltage A1: AC 115V A2: AC 230V A3: AC 380V D1: DC 12V D2: DC24V

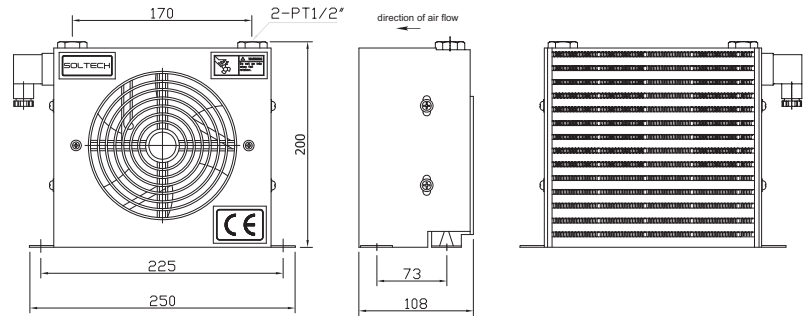

### ※SPECIFICATION

DESCRIPTION	UNIT	AC 115V	AC 230V	AC 380V	DC 12V	DC 24V
FREQUENCY	Hz	50/60	50/60	50/60	---	---
POWER	W	45/37	45/37	30/25	---	---
CURRENT	A	0.5/0.6	0.27/0.23	---	2.5	0.58
SPEED	R.P.M.	2850/3450	2850/3450	---	3350	3350
AIR-FLOW	m <sup>3</sup> /h	457/553	457/553	---	500	420
PROTECTION		IP54	IP54	---	---	---
NOISE	dB(A)	42/48	42/48	---	51	51
SAFETY REF.		CE	CE	---	---	---

### 【AW0608-CA\*】

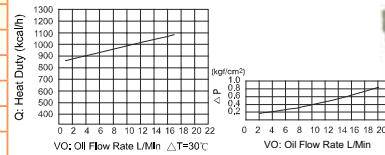

### ※MODEL NUMBER DESIGNATION

AW	06	08	C	A1
Series No.	Fan Size	Radiator Model No.	Fan Case	Voltage A1: AC 115V A2: AC 230V A3: AC 380V D1: DC 12V D2: DC24V

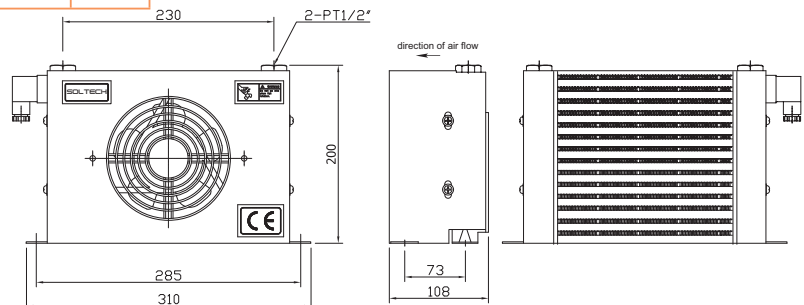

### ※SPECIFICATION

DESCRIPTION	UNIT	AC 115V	AC 230V	AC 380V	DC 12V	DC 24V
FREQUENCY	Hz	50/60	50/60	50/60	---	---
POWER	W	45/37	45/37	30/25	---	---
CURRENT	A	0.5/0.6	0.27/0.23	---	2.5	0.58
SPEED	R.P.M.	2850/3450	2850/3450	---	3350	3350
AIR-FLOW	m <sup>3</sup> /h	457/553	457/553	---	500	420
PROTECTION		IP54	IP54	---	---	---
NOISE	dB(A)	42/48	42/48	---	51	51
SAFETY REF.		CE	CE	---	---	---

### 【AW0608L-CA\*】

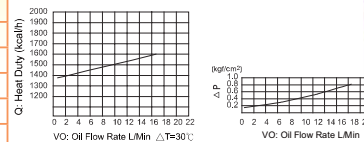

### ※MODEL NUMBER DESIGNATION

AW	06	08L	C	A1
Series No.	Fan Size	Radiator Model No.	Fan Case	Voltage A1: AC 115V A2: AC 230V A3: AC 380V D1: DC 12V D2: DC24V

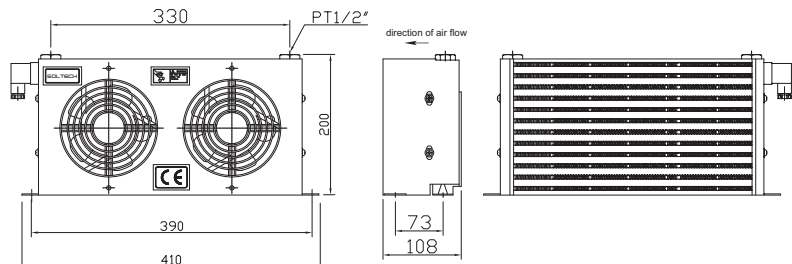



# ACCESSORIES

## AIR-OIL PLATE-FIN HEAT EXCHANGER- DRAIN TYPE

### ※MODEL NUMBER DESIGNATION

<b>AL</b>	<b>190</b>
Series No.	Radiator Model 190: PT/Rc 1/2" 404: PT/Rc 1/2" 608: PT/Rc 3/8" 609: PT/Rc 1/2"

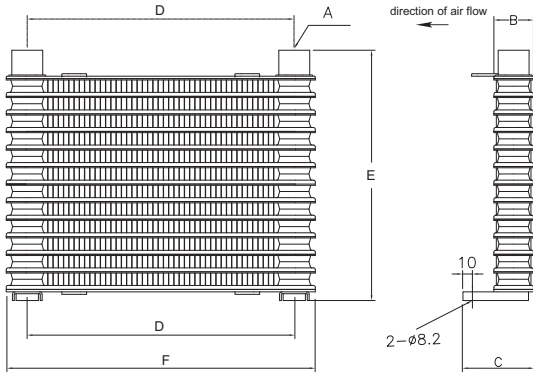

### 【AL-\*\*\*】



AL404

AL608

AL190

	A (Rc/PT)	B	C	D	E	F	WEIGHT
AL190	1/2"	32(1.26)	56(2.20)	190(7.48)	167(6.57)	220(8.66)	0.5
AL404	1/2"	42(1.65)	66(2.60)	217(8.54)	203(7.99)	250(9.84)	1
AL608	3/8"	32(1.26)	56(2.20)	217(8.54)	203(7.99)	250(9.84)	0.75
AL609	1/2"	32(1.26)	56(2.20)	217(8.54)	203(7.99)	250(9.84)	0.75

UNIT: M.M./INCH

### ※SPECIFICATION

DESCRIPTION	UNIT	AC 115V	AC 230V	AC 380V	DC 12V	DC 24V
FREQUENCY	Hz	50/60	50/60	50/60	---	---
POWER	W	45/37	45/37	30/25	---	---
CURRENT	A	0.5/0.6	0.27/0.23	---	2.5	0.58
SPEED	R.P.M.	2850/3450	2850/3450	---	3350	3350
AIR-FLOW	m <sup>3</sup> /h	457/553	457/553	---	500	420
PROTECTION		IP54	IP54	---	---	---
NOISE	dB(A)	42/48	42/48	---	51	51
SAFETY REF.		CE	CE	---	---	---

### 【AL-\*\*\*-A\*】

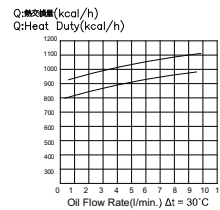

### ※MODEL NUMBER DESIGNATION

<b>AL</b>	<b>404</b>	<b>A1</b>
Series No.	Radiator Model 404: PT/Rc 1/2" 608: PT/Rc 3/8" 609: PT/Rc 1/2"	Voltage A1: AC 115V A2: AC 230V A3: AC 380V D1: DC 12V D2: DC24V

	A (Rc/PT)	B	C	WEIGHT
AL-404-A	1/2"	42(1.65)	110(4.33)	2.25
AL-608-A	3/8"	32(1.26)	120(4.72)	2.0
AL-609-A	1/2"	32(1.26)	120(4.72)	2.0

UNIT: M.M./INCH

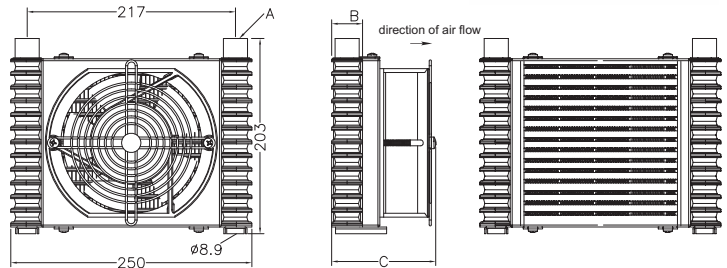

### ※SPECIFICATION

DESCRIPTION	UNIT	AC 115V	AC 230V	AC 380V	DC 12V	DC 24V
FREQUENCY	Hz	50/60	50/60	50/60	---	---
POWER	W	45/37	45/37	30/25	---	---
CURRENT	A	0.5/0.6	0.27/0.23	---	2.5	0.58
SPEED	R.P.M.	2850/3450	2850/3450	---	3350	3350
AIR-FLOW	m <sup>3</sup> /h	457/553	457/553	---	500	420
PROTECTION		IP54	IP54	---	---	---
NOISE	dB(A)	42/48	42/48	---	51	51
SAFETY REF.		CE	CE	---	---	---

### 【AL\*\*\*-CA\*】

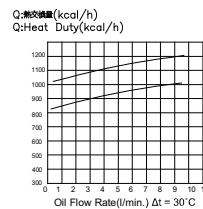

### ※MODEL NUMBER DESIGNATION

<b>AL</b>	<b>608</b>	<b>A1</b>
Series No.	Radiator Model 404: PT/Rc 1/2" 608: PT/Rc 3/8" 609: PT/Rc 1/2"	Voltage A1: AC 115V A2: AC 230V A3: AC 380V D1: DC 12V D2: DC24V

	A (Rc/PT)	B	C	WEIGHT
AL-404-CA	1/2"	42(1.65)	110(4.33)	2.25
AL-608-CA	3/8"	32(1.26)	120(4.72)	2.6
AL-609-CA	1/2"	32(1.26)	120(4.72)	2.6

UNIT: M.M./INCH

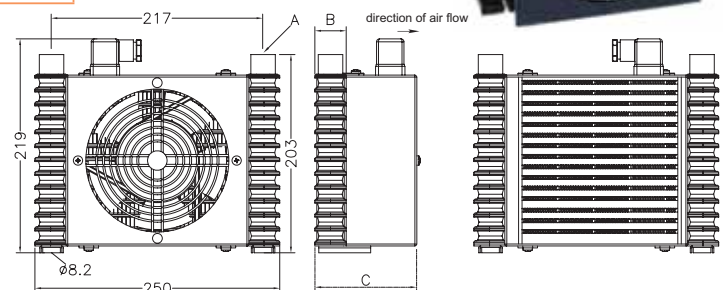



# ACCESSORIES

## AIR-OIL PLATE-FIN HEAT EXCHANGER- DRAIN TYPE, COOLING PUMP

### ※SPECIFICATION

DESCRIPTION	UNIT	AC 115V	AC 230V	AC 380V	DC 12V	DC 24V
FREQUENCY	Hz	50/60	50/60	50/60	---	---
POWER	W	45/37	45/37	30/25	---	---
CURRENT	A	0.5/0.6	0.27/0.23	---	2.5	0.58
SPEED	R.P.M.	2850/3450	2850/3450	---	3350	3350
AIR-FLOW	m <sup>3</sup> /h	457/553	457/553	---	500	420
PROTECTION		IP54	IP54	---	---	---
NOISE	dB(A)	42/48	42/48	---	51	51
SAFETY REF.		CE	CE	---	---	---

### {AL-\*\*\*-4A\*}

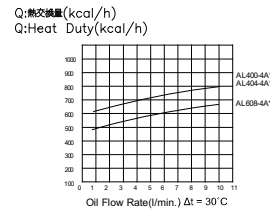

### ※MODEL NUMBER DESIGNATION

AL	404	4	A1
Series No.	Radiator Model 404: PT/Rc 1/2" 608: PT/Rc 3/8" 609: PT/Rc 1/2"	Fan Size 4" inch	Voltage A1: AC 115V A2: AC 230V A3: AC 380V D1: DC 12V D2: DC24V

	A (Rc/PT)	B	C	WEIGHT
AL-404-4A	1/2"	42(1.65)	98(3.86)	1.75
AL-608-4A	3/8"	32(1.26)	88(3.46)	1.5
AL-609-4A	1/2"	42(1.65)	88(3.46)	1.5

UNIT: M.M./INCH

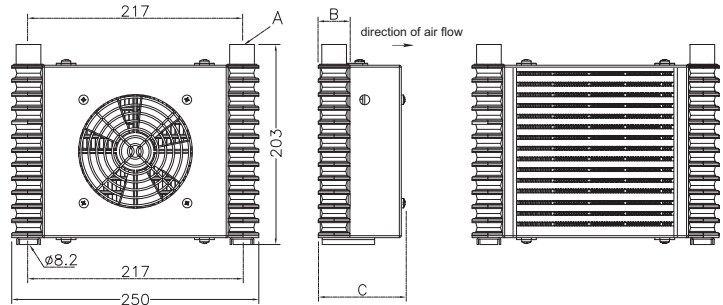

H

### ※MODEL NUMBER DESIGNATION

TC	6	130
Model No.	Power	Pump Size (M.M.)
		180: 180
		240: 240
	1: 1 Hp	380: 380
		180: 180
		290: 290
	2: 1/2 Hp	155: 155
		220: 220
		350: 350
	4: 1/4 Hp	130: 130
180: 180		

A By-Pass Valve to Avoid Surge Back-Pressure When Started With Cold Oil.

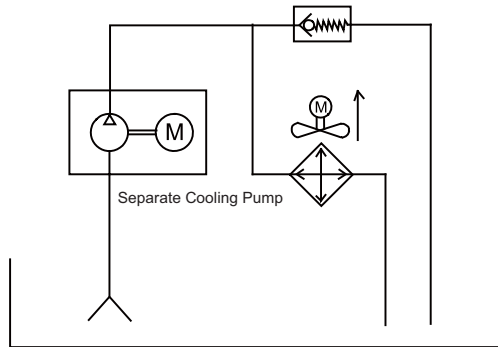

Separate Cooling Method

### {TC-6130}

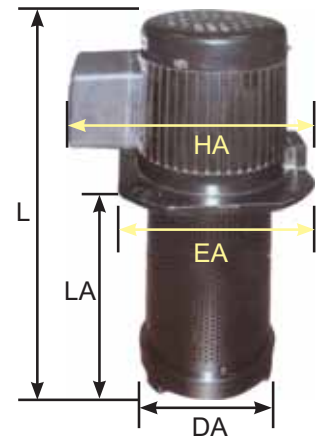

### ※SPECIFICATION

Model	Power (Hp)	Flow (l/min)	L (M.M.(INCH))	LA (M.M.(INCH))	DA (M.M.(INCH))	HA (M.M.(INCH))	EA (M.M.(INCH))	Outlet Port Rc/PT
TC-6130	1/6	20	275(10.8)	130(5.1)	90(3.5)	160(6.3)	128(5.0)	1/2"
TC-6180	1/6	20	325(12.8)	180(7.1)	90(3.5)	160(6.3)	128(5.0)	1/2"
TC-4155	1/4	50	341(13.4)	155(6.1)	126(5.0)	191(7.5)	158(6.2)	3/4"
TC4220	1/4	50	406(16.0)	220(8.7)	126(5.0)	191(7.5)	158(6.2)	3/4"
TC-4350	1/4	50	536(21.1)	350(13.8)	126(5.0)	191(7.5)	158(6.2)	3/4"
TC-2180	1/2	80	385(15.2)	180(7.1)	126(5.0)	196(7.7)	171(6.7)	1"
TC-2290	1/2	80	495(19.5)	290(11.4)	126(5.0)	196(7.7)	171(6.7)	1"
TC-1180	1	120	400(15.7)	180(7.1)	151(5.94)	191(7.5)	185(7.28)	1"
TC-1240	1	120	460(18.1)	240(9.4)	151(5.94)	196(7.7)	185(7.28)	1"
TC-1380	1	120	600(23.6)	380(15.0)	151(5.94)	196(7.7)	185(7.28)	1"

UNIT: M.M./INCH